

PERFORMANCE III
LIGHTLIFT 26.14

230kg
capacity

FEATURES

- 230kg capacity with no restriction on the entire working diagram
- Large working area: 25,7m height and 13,6m constant outreach, with trajectory flush against the wall
- Fast and precise movements
- 10m up & over to allow easy clearance of obstacles at height.



Length of the machine in transport configuration is less than 6m thanks to the detachable basket.

Articulated boom with double telescopic steel boom, in Domex® 700 with wall thickness from 3 to 5mm for max service life and stiffness.



the future is now

Hinowa®



Height of the machine in transport configuration is less than 2m allowing easy passage through the doors.



▲ Lengthened undercarriage for greater stability, improved angle of attack (22°) and lowering of ground pressure during translation, equipped with Auto2Speed technology for maximum speed or torque depending on the working conditions.



▶ Large forklift pockets to allow easy lifting with forklift or tele-handler to load, unload and transport the machine.



▶ New Kubota Diesel D902 3 cylinder water cooled engine, meets the Tier 4 standards, with 40 litres capacity tank for an increased range.



▶ Incredible widening of the undercarriage, from 990mm allowing easy passage through narrow and cramped places, to 1490mm for an enhanced lateral stability.



Double air-water line allowing the use of varied tools in the basket (1/4", 1/2").



Heavy Duty anchor hooks for improved safety in transport.



New low energy LED lamps on outriggers. Heavy Duty lifting hooks on outriggers for quick and easy positioning with crane.



Assisted automatic stabilization on slopes, up to 16°. Allows a ground clearance of 700mm with machine completely stabilized, with slope control during destabilization.

the future is now



▲
New Zistaplex® hydraulic hose treatment, anticorrosive up to 600 hours in salt spray tests.

▼
Main battery maintenance free AGM type for start & stop, with charge maintainer.



▼
Hinowa®

▶
110V-220V electric motor with improved torque.



▲ Outrigger block valves doubled for safety, also protected from accidental impact.



▲ Auxiliary connector for external devices, telematics and fleet tracking.

Preprogrammed for optional anti-entrapment device in the basket.

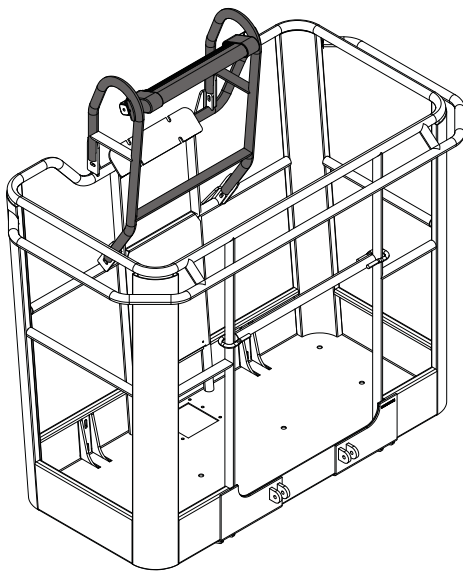

the future is now



- ▼
- Machine automatically shuts down after 2 hours of inactivity saving battery power.
 - Split hydraulic and electrical systems to simplify the service
 - Software and safety controls in compliance with new regulations EN280:2013 AND 13849
 - Remote software version updates via satellite from the remote control.

360°

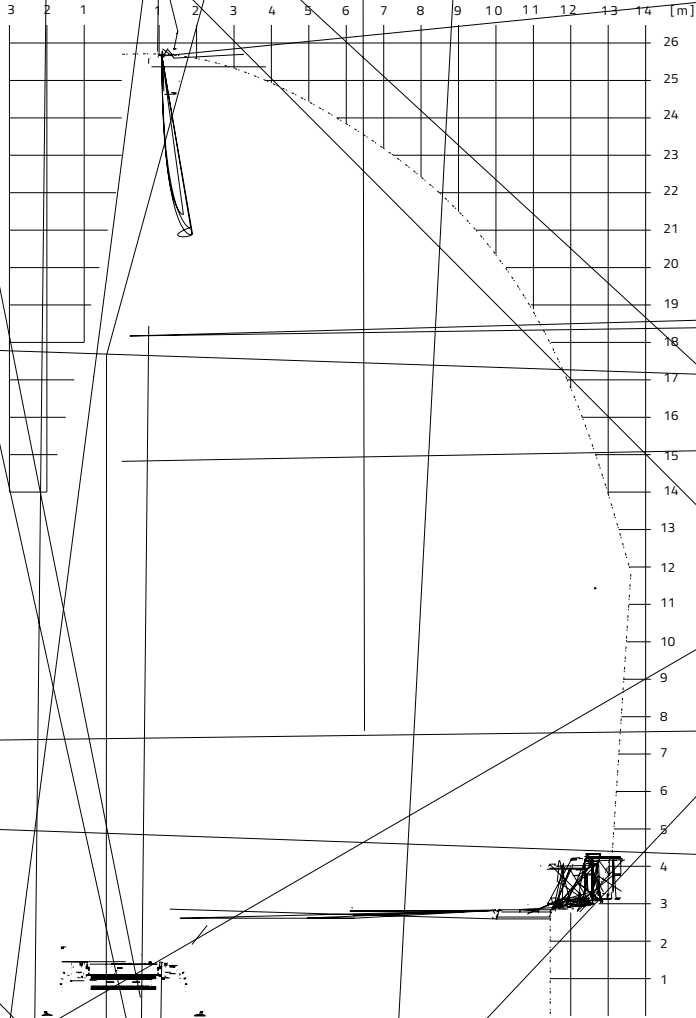



HINOWA S.p.A.

www.hinowa.com - info@hinowa.com

Via Fontana • 37054 Nogara • Verona • ITALY

Tel. +39 0442.539100 • Fax +39 0442.539075