

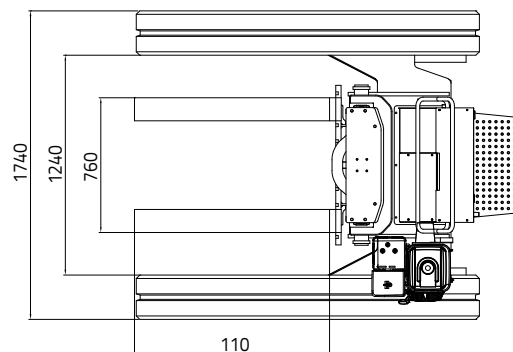

TRACKED PALLET JACK TP1800

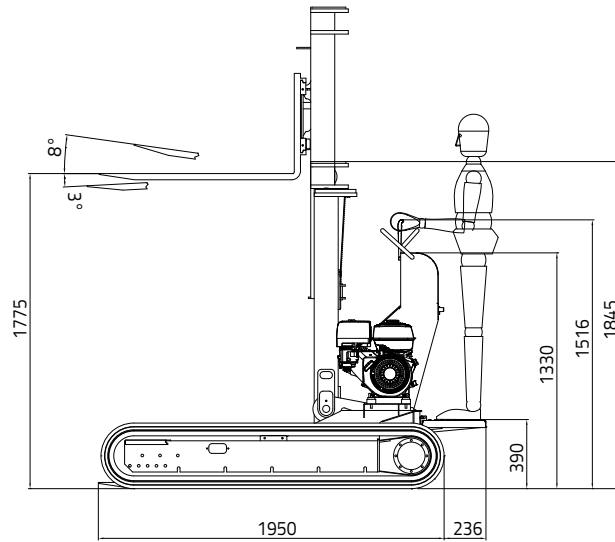

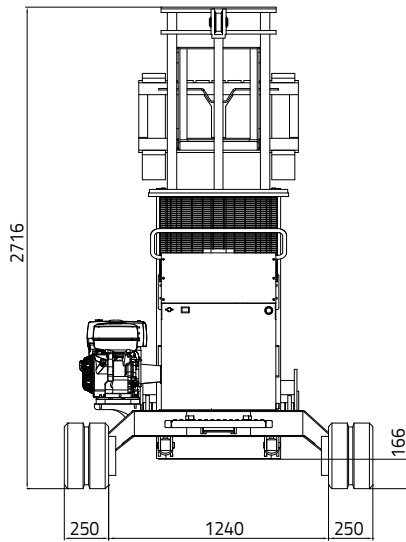

TRACKED PALLET JACK TP1800

PETROL ENGINE

Brand.....HONDA
 Type.....GX390
 Pistons no. and displacement.....single-cylinder 389 cc
 Max gross power @ rpm 11,7 HP - 8,7 kW @ 3600 rpm
 Setting rpm3500 rpm
 Electrical start 12 volt

DISTRIBUTOR

Typemechanical

HYDRAULIC PUMPS

Number and typen° 3 gear pumps at 4 cc
 Liters/min capacity 15 l/1'
 Pressure 185 bar P1 - P2 /140 bar P3
 Tank capacity.47 liters

DRIVE MOTORS

Typeorbital
 Displacement 100 cc

TRACKS

Track tensionerto grease
 Track width250 mm
 Roller for side5
 Traslation speed 1,5 - 2,2 km/h
 Fixed undercarriage 1740 mm
 Capacity 1800 kg
 Ground pressure.....0,38 kg/cc
 Max upper slant 20° (36,4%)

OPERATING WEIGHT (without operator) 1200 kg

PETROL FUEL TANK

Petrol 6,5 liters