

**LL17.75 MK2**

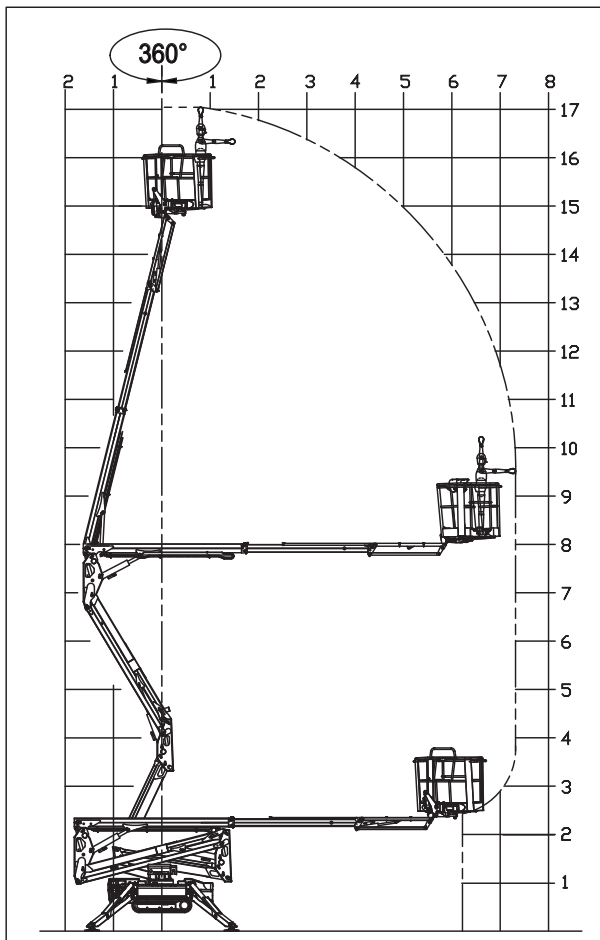

**MAX. KORBTRAGLAST 230 KG**

(2 Personen 80x2=160 kg + Werkzeugkasten 70 kg)

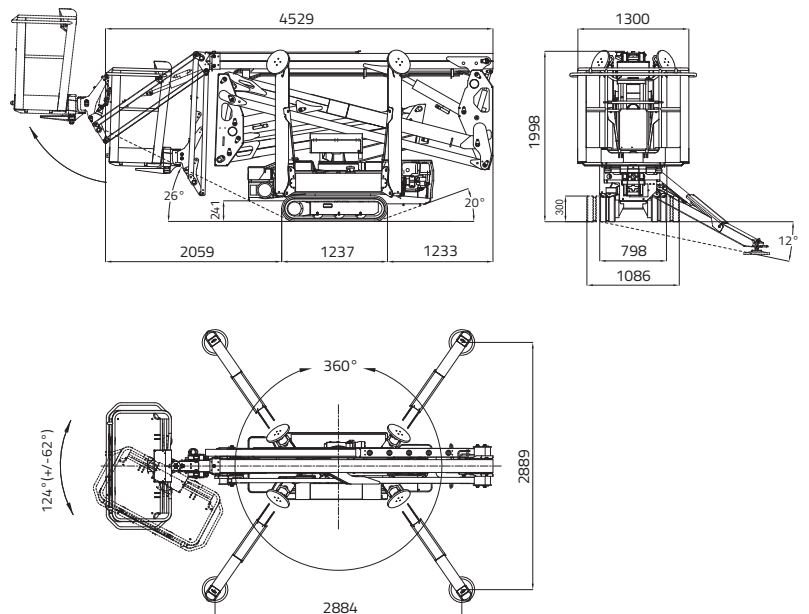

17,06 m



7,50 m



4,53 m



4,17 m



1,99 m



1.335 x 690 x h. 1.100 mm



124° (+/-62°)



16° / 28,7%



798 - 1086 mm



1.731 daN - 2,45 daN/cm<sup>2</sup>



2.884 x 2.889 mm



III S – Abstütz- und Einfahrtomatik  
serienmässig



Kabelfernbedienung



GPRS-GPS



R.A.H.M.



Elektromotor mit Lithium-Batterien  
4,8 kWh  
Optional

**LL17.75 MK2**



**BENZINMOTOR**

Hersteller ..... HONDA  
Modell ..... GX390  
Zylinder und Hubraum .....  
..... einzylindrig 389 cm<sup>3</sup>  
Max. Bruttoleistung .....  
..... 11,7PS - 8,7 kW @ 3600 U/min  
Elektrischer Anlasser ..... 12 volt

**DIESELMOTOR**

Hersteller ..... HATZ  
Modell ..... 1B40 - HD Autovore  
Zylinder und Hubraum .....  
..... einzylindrig 462 cm<sup>3</sup>  
Max. Bruttoleistung .....  
..... 10PS - 7,5 kW @ 3600 U/min  
Elektrischer Anlasser ..... 12 volt

**ELEKTROANLAGE - LITHIUM-ION**

Lithium Akkupack ..... 4,8 kWh  
Batterielader an Bord .....  
..... 220V 50Hz oder 110V 50Hz  
Arbeitsautonomie ..... 4-5 h  
Ladezeit bei komplett leeren Batterien .....  
..... .4 h (Schätzwert)  
Ladezeit bis 80% bei komplett leeren Batterie-  
rien ..... .2 h (Schätzwert)

**HYDRAULIKPUMPE**

Elektromotor ..... Nr. 2 Zahnradpumpen

**RAUPENFAHRWERK**

Kettenspanner ..... mit Schmierfett  
Stützrollen pro Seite ..... 3 + Schlitten

Fahrgeschwindigkeit mit 3. Geschwindigkeit Auto2speed:

- Benzinmotor ..... 0,6 - 1,4 - 2,7 km/h  
- Dieselmotor ..... 0,7 - 1,8 - 3,6 km/h  
- Elektranlage lithium ..... 0,4 - 0,8 - 1,6 km/h

MASCHINENGEWICHT Verbrennungsmotor ..... 2230 kg

MASCHINENGEWICHT Elektranlage lithium ..... 2300 kg

MAX. WINDGESCHWINDIGKEIT ..... 12,5 m/s