

# LL26.14 MK2

**PORTATA MAX 230 KG**  
(2 persone 80x2=160 kg + attrezzatura 70 kg)

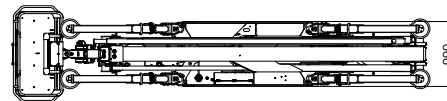

AREA TOTALE

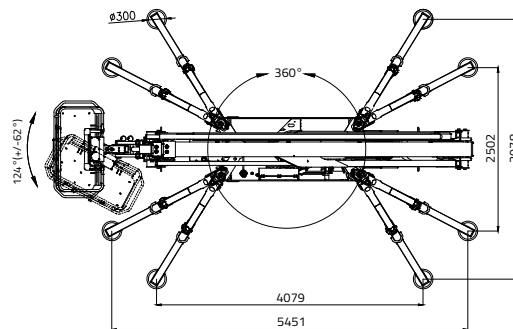
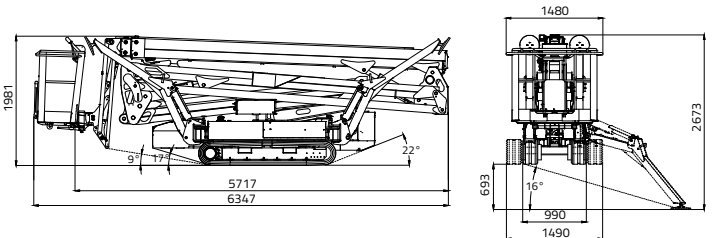
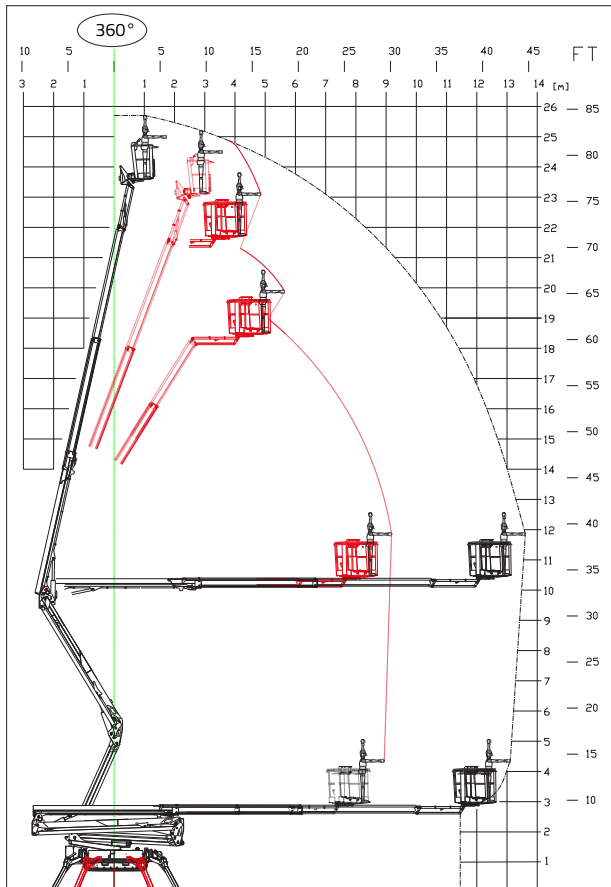
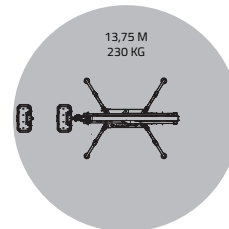

AREA PARZIALE

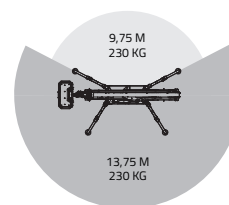

AREA RIDOTTA

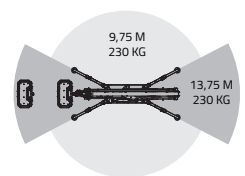

25,70 m



13,75 m ■ 9,75 m in area ridotta



6,34 m



5,98 m



1,98 m



1.335 x 690 x h. 1.100 mm



124° (+/-62°)



16° / 28,7%



990 - 1490 mm



3124 daN - 4,42 daN/cm<sup>2</sup>



Totale 4.079 x 3.978 mm  
Ridotta 5.451 x 2.502 mm  
Parziale 3240 x (4.079/5.451) mm



Stabiliz. e destabiliz. automatica IIS di serie



Filocomando



GPRS-GPS



R.A.H.M.



Pacco batterie al litio  
7,6 kWh



Bi-energy (Diesel + Pacco batterie al litio)

# LL26.14 MK2



## MOTORE DIESEL

Marca .....KUBOTA  
Tipo .....D902 Autorev  
Cilindri e cilindrata ..... 898 cm<sup>3</sup>  
Potenza lorda max.....  
..... 21,6 HP - 16,1 kW @ 3200 rpm  
Avviamento elettrico ..... 12 volt

## SISTEMA LITHIUM-ION

Pacco batterie al litio ..... 7,6KWh  
Caricabatterie a bordo.....  
..... 220V o 110V +-30V 50-60 Hz  
Autonomia di lavoro..... 4-5 h  
Tempo di ricarica a batterie completamente  
scariche.....4 h (indicativo)  
Tempo di ricarica all'80% da batterie completamente  
scariche..... 2 h (indicativo)

## POMPA IDRAULICA

Motore elettrico .....2 ad ingranaggi

## CINGOLATURA

Tendicingolo ..... a grasso  
Rulli per lato .....6 + slitta

Velocità di traslazione con 2<sup>a</sup> velocità Auto2speed:

- motore diesel..... 1,1 - 2 km/h  
- motore lithium-ion..... 0,7 - 1,2 km/h

PESO MACCHINA diesel .....4365 kg

PESO MACCHINA lithium-ion .....4384 kg

PESO MACCHINA bi-energy .....4560 kg

VELOCITÀ MAX VENTO ..... 12,5 m/s