

GL14.70

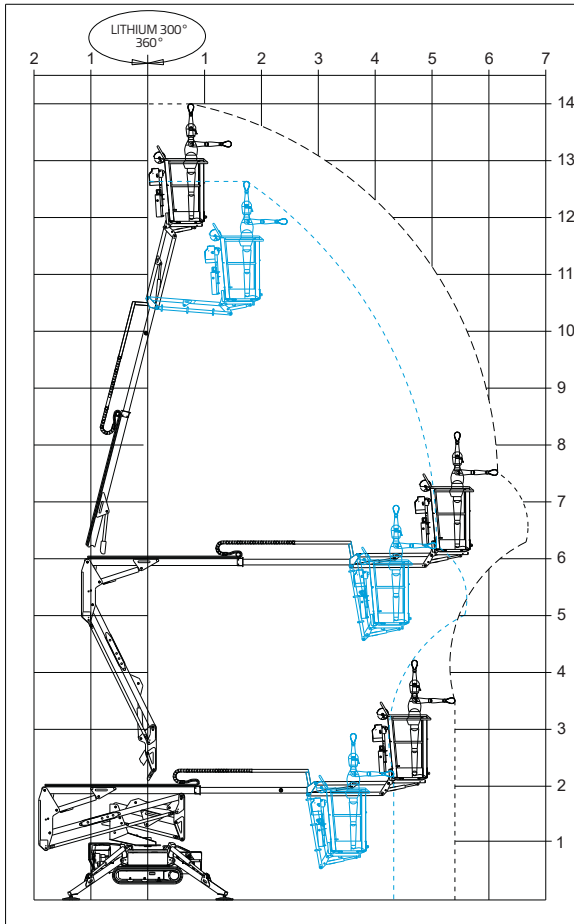



PORTATA 120 KG

(1 persona 80 kg + attrezzatura 40 kg)



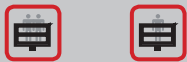
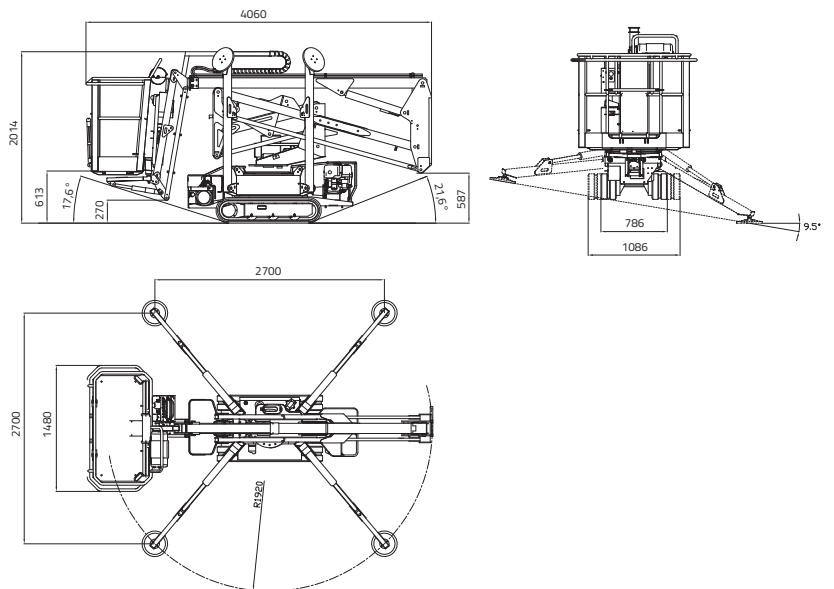

PORTATA 200 KG

(2 persone 80x2=160 kg + attrezzatura 40 kg)



	12,68 m	14,00 m
	5,66 m	7,00 m
	4,06 m	
	3,87 m	
	2,01 m	

	1.335 x 690 x h 1.100 mm
	15° / 26,8%
	786 - 1086 mm
	1330 daN - 1,9 daN/cm ²
	2700 x 2700 mm

	Stabiliz. e destabiliz. automatica IIS di serie
	Radiocomando
	GPRS-GPS
	R.A.H.M.

 Pacco batterie al litio
4,8 kWh
Opzionale



MOTORE BENZINA

Marca HONDA
 Tipo GX390
 Cilindri e cilindrata monocilindrico
 389 cm³
 Potenza lorda max
 11,7HP - 8,7 kW @ 3600 rpm (GX390)
 Avviamento elettrico 12 volt

MOTORE DIESEL

Marca HATZ
 Tipo 1B40 - HD Autorev
 Cilindri e cilindrata monocilindrico
 462 cm³
 Potenza lorda max
 10 HP - 7,5 kW @ 3600 rpm
 Avviamento elettrico 12 volt

SISTEMA LITHIUM-ION

Pacco batterie al litio 4,8 kWh
 Caricabatterie a bordo
 220V 50Hz o 110V 50Hz
 Autonomia di lavoro 4-5 h
 Tempo di ricarica a batterie completamente
 scariche 4 h (indicativo)
 Tempo di ricarica all'80% da batterie com-
 pletamente scariche 2 h (indicativo)

MOTORE ELETTRICO

Standard 230V / 50 Hz - 2,2 kW
 Optional 110V / 50 Hz - 2,2 kW

CINGOLATURA

Tendicingolo a grasso
 Rulli per lato 3 + slitta

Velocità di traslazione:

- motore termico 1,4 - 2,8 km/h
 - motore lithium 1,2 - 2,4 km/h

PESO MACCHINA motore benzina/diesel 1700 kg

PESO MACCHINA motore lithium 1810 kg

VELOCITÀ MAX VENTO 12,5 m/s