

HS400 SELF LOADING VERSION

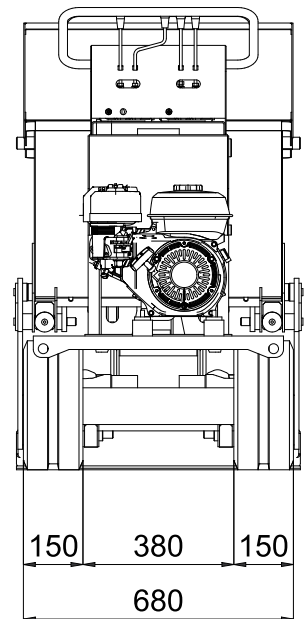
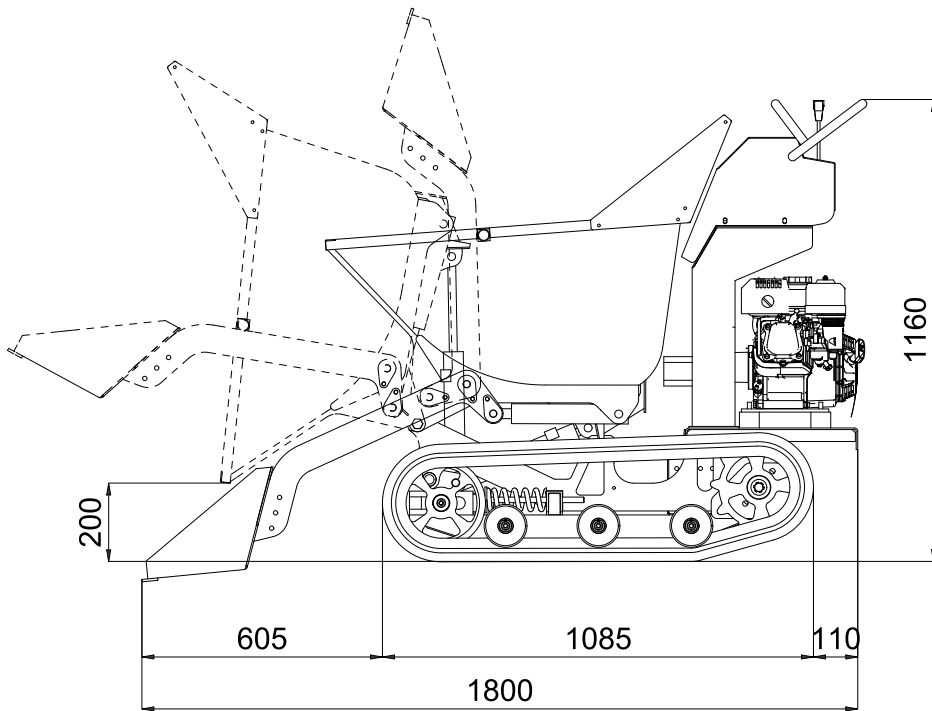

HS400

SELF LOADING VERSION

PETROL ENGINE

Brand and type.....HONDA GX200
Pistons and displacementsingle-cylinder 196 cc
Max gross power5,5 HP - 4,1 kW @ 3600 rpm
Startingmanual
Fuel tank3,1 liters

DISTRIBUTOR

Type mechanical

HYDRAULIC PUMPS

Number and typen° 2 gear pumps

TRACKS

Track tensionerspring
Track width150 mm
Rollers per side.....3
Fixed undercarriage.....680 mm

PERFORMANCE

Translation speed1,7 km/h
Max. inclination25° (46,6%)
Granted noise levelLwa 101 dB

CAPACITY 400 kg

DUMPER BED CAPACITY

Rated volume (ISO 6483)0,20 m³
Struck volume0,16 m³

OPERATING WEIGHT (without operator).....316 kg