

HS701 HIGH-TIP DUMPER BED

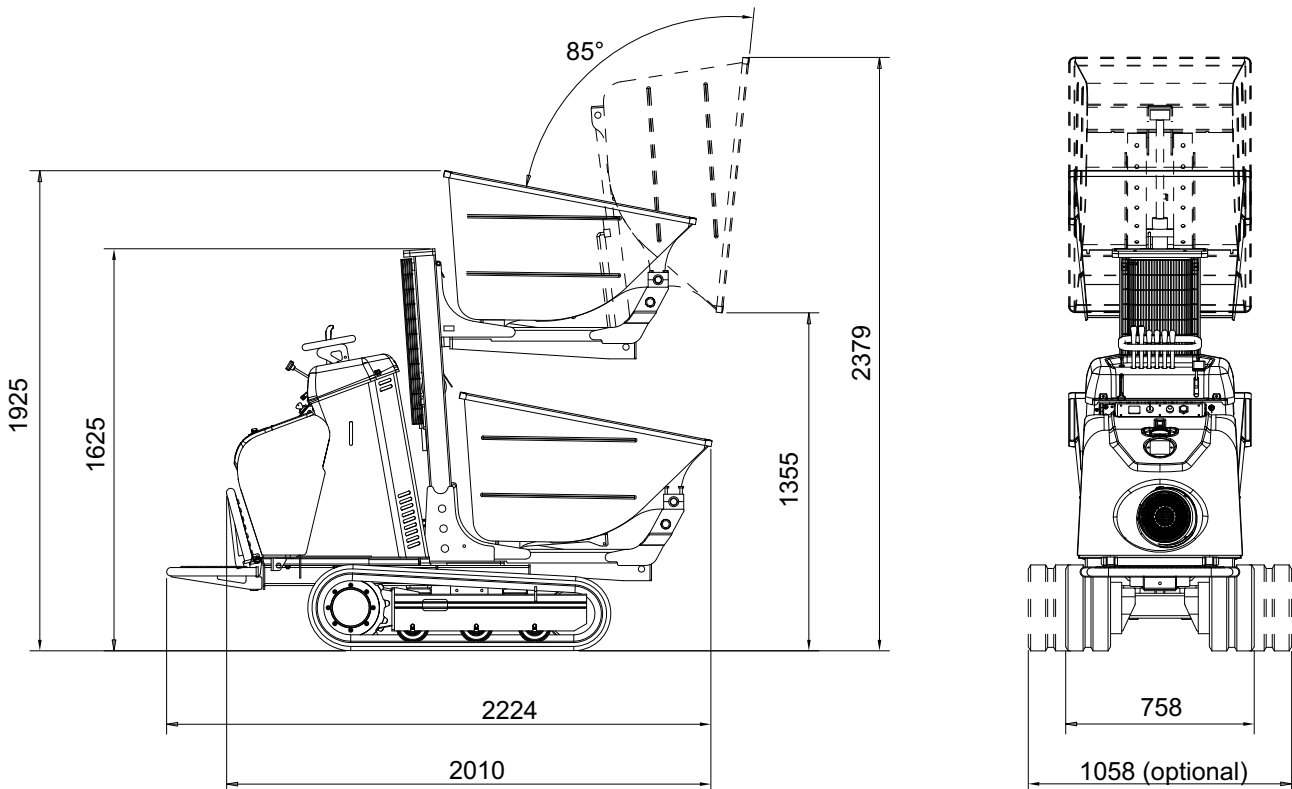

HS701

HIGH-TIP DUMPER BED

PETROL ENGINE

Brand and type.....	Honda GX270
Pistons and displacement	single-cylinder 270 cc
Max gross power	8,4 HP - 6,3 kW @ 3600 rpm
Starting	manual
Fuel tank	5,3 liters

DIESEL ENGINE

Brand and type.....	KUBOTA OC 95
Pistons and displacement	single-cylinder 416 cc
Max gross power	9,4 HP - 7,0 kW @ 3600 rpm
Starting	electric 12 volt
Fuel tank	5,5 liters

DISTRIBUTOR

Type	mechanical
------------	------------

HYDRAULIC PUMPS

Number and type	n° 3 gear pumps
-----------------------	-----------------

TRACKS

Track tensioner.....	grease
Track width	180 mm
Rollers per side	3
Undercarriage width open/close	758 - 1058 mm

PERFORMANCE

Translation speed petrol engine	2,2 - 3,3 km/h
Translation speed diesel engine	2,2 - 3,3 km/h
Max. inclination	15° (diesel version and dumper bed lowered)
Granted noise level	Lwa 101 dB

CAPACITY	550 kg
-----------------------	--------

DUMPER BED CAPACITY

Rated volume (ISO 6483)	0,29 m ³
Struck volume	0,24 m ³

OPERATING WEIGHT (without operator)

Fixed/widening undercarriage - petrol engine.....	620 kg / 700 kg
Fixed/widening undercarriage - diesel engine.....	660 kg / 740 kg